

Railway voltage sensors VS range

Electronic technology for rolling stock and infrastructure

3

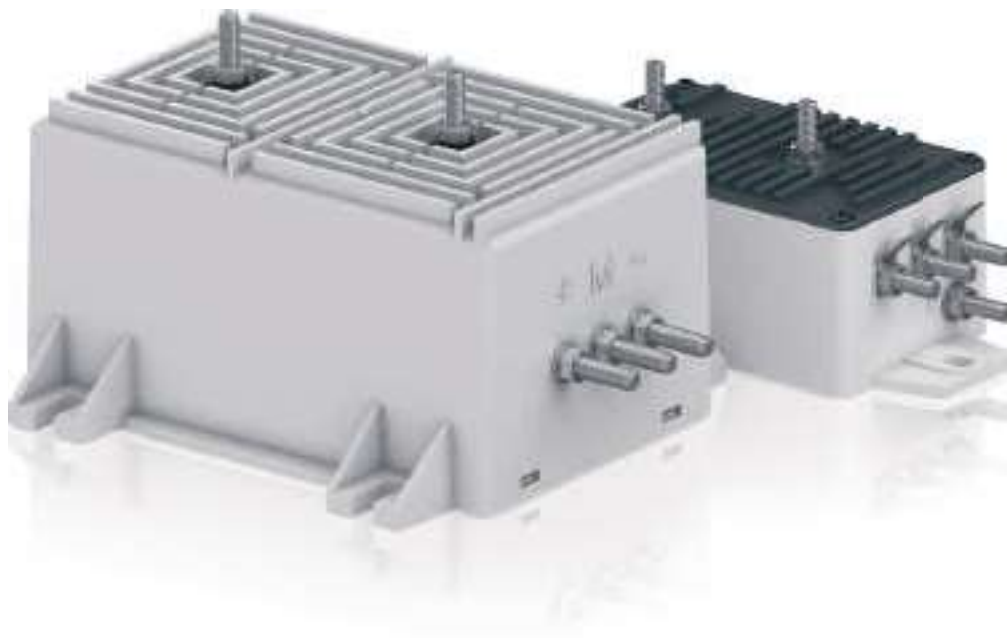

100% electronic a great leap forward

To push the performance barriers back ever further, VS sensors are made 100% electronic. Our sensors are the first ones on the market to incorporate this innovation. They prove themselves every day and give their users the edge in a broad range of applications. This guarantees you unbeatable dynamic performances that give optimal slaving of customer equipment while complying with the latest standards in force.

VS sensors are perfect for use in sectors such as railways, mining and control in hazardous environments.

VS voltage sensors and CS current sensors together constitute an offer the railway industry cannot afford to ignore.



Incomparable protection against magnetic fields

VS sensors are conceived, designed and renowned for their unrivalled immunity to ambient magnetic fields. Although they are in continuous proximity of powerful currents capable of distorting their measurements, this does not, in fact, occur. Their accuracy is rock-solid and once set to measure a particular voltage, that is what they measure – that and nothing else.

Perfect efficiency in every environment

The VS range has been designed for applications in difficult environments such as on-board railway equipment (power converters, auxiliary converters for heating, ventilation and air conditioning) and the mining industry. Their robust design and excellent performances (e.g. operating range between -40° and $+85^{\circ}\text{C}$) make VS voltage sensors ideal for use in other very demanding applications (marine, wind-power, ozone generators, etc.).

Going beyond ordinary standards

PETERCEM have been ISO 9001 certified since 1993 and our sensors bear the CE label. This ongoing striving after quality has always been the hallmark of a company where excellence and safety are part of the culture, from design right through to production.

This culture is the result of continuous research to make technical progress and meet our customers' demands.

The chief selling-point of VS sensors is their quality. Compliance with EN 50121-X for electromagnetic disturbance and EN 50155 for their high-tech electronic design is proof of their ability to comply with the most detailed constraints as well as major demands. The fact that each individual sensor is subjected to rigorous testing such as sensor burn-in is proof of the importance PETERCEM attribute to quality.

VS sensors meet the various security standards in force such as EN 50124-1 for electrical insulation and NFF 16101-NFF 16102 for fire-smoke resistance.

Environment-friendly

PETERCEM have long been concerned with the protection of the environment, as proved by the ISO 14001 certification they received in 1998. This environmental approach is particularly noticeable in production of the VS range in the reduction of the number of components, in the use of a low-energy manufacturing procedure and the use of recyclable packing. The products in use are also characterized by their reduced energy consumption.

Quality that goes beyond standards



PETERCEM have applied the notion "Small is beautiful" to its products.

By integrating the notion of reduced size into their VS sensors, PETERCEM have brought miniaturization to a point of perfection.

This miniaturization gives great flexibility of installation. The great breakthrough with VS sensors is that they are 100% electronic. This makes it possible to put cutting-edge technology into the smallest possible space. Everything is integrated; in other words everything is inside to leave as much room as possible outside.

Optimized electronic performance

The electrical performances of VS sensors are genuinely customized to a variety of demands and meet the severest constraints. VS sensors give the best accuracy and performance for money on the market. And their performances really come up to your expectations.

Flexibility of use

All our products have been conceived and designed so that installation and use are as simple as possible. Flexibility of installation and operation obtained using a range of connector variants mean that VS sensors are very easy to use. In fact, high-tech sensors have never been as easy to use.



PETERCEM – because your needs deserve exact science

EM010 ... EM020 railway voltage sensors

For rolling stock and infrastructure

600 to 5000 V - Closed loop technology

3

Closed loop Hall effect technology

Closed loop Hall effect technology also allows for voltage measurement.

For calibrated EM010 sensors, the voltage to be measured is applied directly to the primary terminals of the sensor.



EM10

Ordering details

Nominal primary voltage U_{PN} V r.m.s.	Secondary current at U_{PN} mA	Supply voltage VDC	Secondary connection	Type	Order code
600	50	$\pm 12 \dots \pm 24$	5 x M5 studs	EM010-9239	EM010-9239
750	50	$\pm 12 \dots \pm 24$	5 x M5 studs	EM010-9240	EM010-9240
1000	50	$\pm 12 \dots \pm 24$	5 x M5 studs	EM010-9371	EM010-9371
1500	50	$\pm 12 \dots \pm 24$	5 x M5 studs	EM010-9317	EM010-9317
2000	50	$\pm 12 \dots \pm 24$	5 x M5 studs	EM020-9318	1SBT182020R9318
3000	50	$\pm 12 \dots \pm 24$	5 x M5 studs	EM020-9319	1SBT183020R9319
4200	50	$\pm 12 \dots \pm 24$	5 x M5 studs	EM010-9394	EM010-9394
5000	50	$\pm 12 \dots \pm 24$	5 x M5 studs	EM010-9354	EM010-9354

Note: technical data available on request.

VS50B ... VS4200B railway voltage sensors

For rolling stock and infrastructure
50 to 4200 V - Electronic technology

Electronic technology

These voltage sensors use the new PETERCEM 100 % electronic technology (the magnetic circuit and Hall probe are no longer required). The voltage to be measured is applied directly to the primary terminals of the sensor. They are specially designed and manufactured to meet the latest railway standards.

Ordering details

Nominal primary voltage V r.m.s.	Secondary current at U _{PN} mA	Supply voltage VDC	Secondary connection	Type	Order code
50	50	±12 ... ±24	4 x M5 studs // 3 x 6.35 x 0.8 Faston	VS50B	1SBT160050R0001
125	50	±12 ... ±24	4 x M5 studs // 3 x 6.35 x 0.8 Faston	VS125B	1SBT160125R0001
250	50	±12 ... ±24	4 x M5 studs // 3 x 6.35 x 0.8 Faston	VS250B	1SBT160250R0001
500	50	±12 ... ±24	4 x M5 studs // 3 x 6.35 x 0.8 Faston	VS500B	1SBT160500R0001
750	50	±12 ... ±24	4 x M5 studs // 3 x 6.35 x 0.8 Faston	VS750B	1SBT160750R0001
1000	50	±12 ... ±24	4 x M5 studs // 3 x 6.35 x 0.8 Faston	VS1000B	1SBT161000R0001
1500	50	±12 ... ±24	4 x M5 studs // 3 x 6.35 x 0.8 Faston	VS1500B	1SBT161500R0001
2000	50	±12 ... ±24	3 x M5 studs	VS2000B	1SBT162000R0001
3000	50	±12 ... ±24	3 x M5 studs	VS3000B	1SBT163000R0001
4000	50	±12 ... ±24	3 x M5 studs	VS4000B	1SBT164000R0001
4200	50	±12 ... ±24	3 x M5 studs	VS4200B	1SBT164200R0001



VS50B to VS1500B



VS2000B to VS4200B

VS50B ... VS1500B railway voltage sensors

For rolling stock and infrastructure

Technical data

3

Utilisation

Electronic sensors to measure DC, AC or pulsating voltages with insulation between primary and secondary circuits.



			VS50B	VS125B	VS250B	VS500B
Nominal primary voltage		V r.m.s.	50	125	250	500
Measuring range	@ ±12 V (±5%) / 1 min/h	V peak	±75	±187.5	±375	±750
Measuring range	@ ±24 V (±5%) / 1 min/h	V peak	±75	±187.5	±375	±750
Not measurable overload	1 sec/hour	V peak	150	375	750	1500
Max. measuring resistance	@ U _{PMAX} & ±12 V (±5%)	Ω	67	67	67	67
Max. measuring resistance	@ U _{PMAX} & ±24 V (±5%)	Ω	188	188	188	188
Min. measuring resistance	@ U _{PN} & ±24 V (±5%)	Ω	0	0	0	0
Secondary current at U _{PN}		mA	50	50	50	50
Accuracy at U _{PN}	@ +25 °C	%	≤±0.9	≤±0.9	≤±0.9	≤±0.9
Accuracy at U _{PN}	-25 ... +70 °C	%	≤±1.5	≤±1.5	≤±1.5	≤±1.5
Accuracy at U _{PN}	-40 ... +85 °C	%	≤±1.7	≤±1.7	≤±1.7	≤±1.7
Offset current	@ +25 °C & ±24 V (±5%)	mA	≤±0.15	≤±0.15	≤±0.15	≤±0.15
Linearity	0.1U _{PN} ... 1.5U _{PN}	%	≤0.3	≤0.3	≤0.3	≤0.3
Delay time		μs	≤10	≤10	≤10	≤10
dv/dt correctly followed		V / μs	≤0.6	≤1.5	≤3	≤6
Bandwidth	-3 dB & R _M = 50 Ω	kHz	≤13	≤13	≤13	≤13
Max. no-load consumption current	@ ±24 V (±5%)	mA	≤50	≤50	≤50	≤50
Dielectric strength	50 Hz, 1 min	kV	3.3	3.3	3.3	3.3
Primary/(Secondary+Screen)						
Dielectric strength Secondary/Screen	50 Hz, 1 min	kV	0.5	0.5	0.5	0.5
Partial discharges : extinction voltage	@10pC, 50 Hz	kV	≥1.1	≥1.1	≥1.1	≥1.1
Supply voltage	±5%	V DC	±12 ... ±24	±12 ... ±24	±12 ... ±24	±12 ... ±24
Mass		kg	0.333	0.333	0.333	0.333
Operating temperature		°C	-40 ... +85	-40 ... +85	-40 ... +85	-40 ... +85
Storage temperature		°C	-50 ... +90	-50 ... +90	-50 ... +90	-50 ... +90

Max. common mode voltage

The following two conditions must be continuously and simultaneously respected:

- 1) $U_{HT+} + U_{HT-} \leq 4.2 \text{ kV peak}$
and
- 2) $|U_{HT+} - U_{HT-}| \leq U_{PMAX}$

General data

- Coated electronic circuit.
- Plastic case and insulating resin are self-extinguishing.
- Direction of the current: A positive primary differential voltage ($U_{HT+} - U_{HT-} > 0$) results in a positive secondary output current from terminal M.
- Protections:
 - of the measuring circuit against short-circuits.
 - of the measuring circuit against opening.
 - of the power supply against polarity reversal.
- Burn-in test in accordance with FPTC 404304 cycle.
- Tightening torque for M5 terminal studs (N.m): 2 N.m.



			VS750B	VS1000B	VS1500B
Nominal primary voltage		V r.m.s.	750	1000	1500
Measuring range	@ ±12 V (±5%) / 1 min/h	V peak	±1125	±1500	±2250
Measuring range	@ ±24 V (±5%) / 1 min/h	V peak	±1125	±1500	±2250
Not measurable overload	1 sec/hour	V peak	2250	3000	4500
Max. measuring resistance	@ U _{PMAX} & ±12 V (±5%)	Ω	67	67	67
Max. measuring resistance	@ U _{PMAX} & ±24 V (±5%)	Ω	188	188	188
Min. measuring resistance	@ U _{PN} & ±24 V (±5%)	Ω	0	0	0
Secondary current at U _{PN}		mA	50	50	50
Accuracy at U _{PN}	@ +25 °C	%	≤±0.9	≤±0.9	≤±0.9
Accuracy at U _{PN}	-25 ... +70 °C	%	≤±1.5	≤±1.5	≤±1.5
Accuracy at U _{PN}	-40 ... +85 °C	%	≤±1.7	≤±1.7	≤±1.7
Offset current	@ +25 °C & ±24 V (±5%)	mA	≤±0.15	≤±0.15	≤±0.15
Linearity	0.1U _{PN} ... 1.5U _{PN}	%	≤0.3	≤0.3	≤0.3
Delay time		μs	≤10	≤10	≤10
dv/dt correctly followed		V/μs	≤9	≤12	≤18
Bandwidth	-3 dB & R _M = 50 Ω	kHz	≤13	≤13	≤13
Max. no-load consumption current	@ ±24 V (±5%)	mA	≤50	≤50	≤50
Dielectric strength Primary/(Secondary+Screen)	50 Hz, 1 min	kV	4.3	5.5	6.5
Dielectric strength Secondary/Screen	50 Hz, 1 min	kV	0.5	0.5	0.5
Partial discharges : extinction voltage	@10pC, 50 Hz	kV	≥1.1	≥2.2	≥2.2
Supply voltage	±5%	VDC	±12 ... ±24	±12 ... ±24	±12 ... ±24
Mass		kg	0.333	0.333	0.333
Operating temperature		°C	-40 ... +85	-40 ... +85	-40 ... +85
Storage temperature		°C	-50 ... +90	-50 ... +90	-50 ... +90

Primary connection

— 2 M5 studs

Standard secondary connections

— 4 M5 studs and 3 Faston 6.35 x 0.8

Options

— Primary connection: 2 separated High Voltage cables.
 — Secondary connection: Shielded cable (2 m), M5 inserts, Lemo connector.

Conformity

EN 50155
 EN 50121-3-2
 EN 50124-1



VS2000B ... VS4200B railway voltage sensors

For rolling stock and infrastructure

Technical data

3

Utilisation

Electronic sensors to measure DC, AC or pulsating voltages with insulation between primary and secondary circuits.



			VS2000B	VS3000B	VS4000B	VS4200B
Nominal primary voltage		V r.m.s.	2000	3000	4000	4200
Measuring range	@ ±12 V (±5%) / 1 min/h	V peak	±3000	±4500	±6000	±6000
Measuring range	@ ±24 V (±5%) / 1 min/h	V peak	±3000	±4500	±6000	±6000
Not measurable overload	1 sec/hour	V peak	6000	9000	12000	12000
Max. measuring resistance	@ U _P MAX & ±12 V (±5%)	Ω	61	61	61	61
Max. measuring resistance	@ U _P MAX & ±24 V (±5%)	Ω	183	183	183	183
Min. measuring resistance	@ U _P N & ±24 V (±5%)	Ω	0	0	0	0
Secondary current at U _P N		mA	50	50	50	50
Accuracy at U _P N	@ +25 °C	%	≤±0.9	≤±0.9	≤±0.9	≤±0.9
Accuracy at U _P N	-25 ... +70 °C	%	≤±1.5	≤±1.5	≤±1.5	≤±1.5
Accuracy at U _P N	-40 ... +85 °C	%	≤±1.7	≤±1.7	≤±1.7	≤±1.7
Offset current	@ +25 °C & ±24 V (±5%)	mA	≤±0.15	≤±0.15	≤±0.15	≤±0.15
Linearity	0.1U _P N ... 1.5U _P N	%	≤0.3	≤0.3	≤0.3	≤0.3
Delay time		μs	≤10	≤10	≤10	≤10
dv/dt correctly followed		V / μs	≤24	≤36	≤48	≤50
Bandwidth	-3 dB & R _M = 50 Ω	kHz	≤13	≤13	≤13	≤13
Max. no-load consumption current	@ ±24 V (±5%)	mA	≤50	≤50	≤50	≤50
Dielectric strength	50 Hz, 1 min	kV	8	12	12	12
Primary/Secondary						
Partial discharges : extinction voltage	@10pC, 50 Hz	kV	≥4.3	≥4.3	≥4.3	≥4.3
Supply voltage	±5%	V DC	±12 ... ±24	±12 ... ±24	±12 ... ±24	±12 ... ±24
Mass		kg	1.5	1.5	1.5	1.5
Operating temperature		°C	-40 ... +85	-40 ... +85	-40 ... +85	-40 ... +85
Storage temperature		°C	-50 ... +90	-50 ... +90	-50 ... +90	-50 ... +90

Max. common mode voltage

The following two conditions must be continuously and simultaneously respected:

- 1) $U_{HT+} + U_{HT-} \leq 10 \text{ kV peak}$
and
- 2) $|U_{HT+} - U_{HT-}| \leq U_{P\text{MAX}}$

General data

- Coated electronic circuit.
- Plastic case and insulating resin are self-extinguishing.
- Direction of the current: A positive primary differential voltage ($U_{HT+} - U_{HT-} > 0$) results in a positive secondary output current from terminal M.
- Protections :
 - of the measuring circuit against short-circuits.
 - of the measuring circuit against opening.
 - of the power supply against polarity reversal.
- Burn-in test in accordance with FPTC 404304 cycle.
- Tightening torque for M5 terminal studs (N.m): 2 N.m.

Primary connection

— 2 M5 studs

Standard secondary connection

— 3 M5 studs

Options

- Primary connection: 2 separated High Voltage cables.
- Secondary connection: shielded cable (2 m), M5 inserts, Lemo connector.
- Nominal secondary current I_{SN} :
 I_{SN} (for U_{PN}) = 20 mA or I_{SN} (for U_{PN}) = 80 mA.

Conformity

EN 50155
EN 50121-3-2
EN 50124-1



VS railway voltage sensors

For rolling stock and infrastructure

Dimensions (mm)

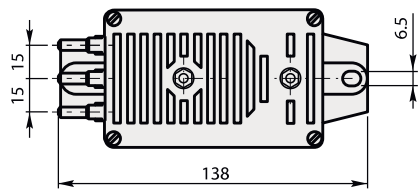
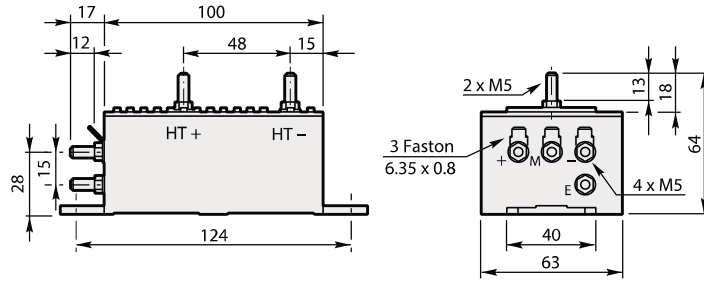

General tolerance: ± 1 mm

Size 0 (VS50B to VS1500B)

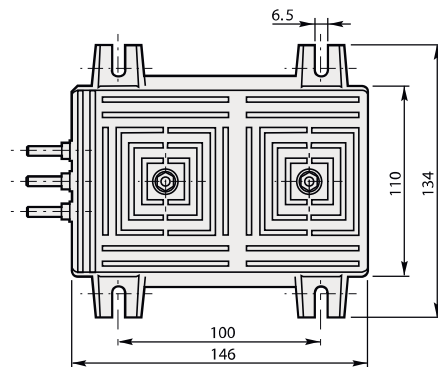
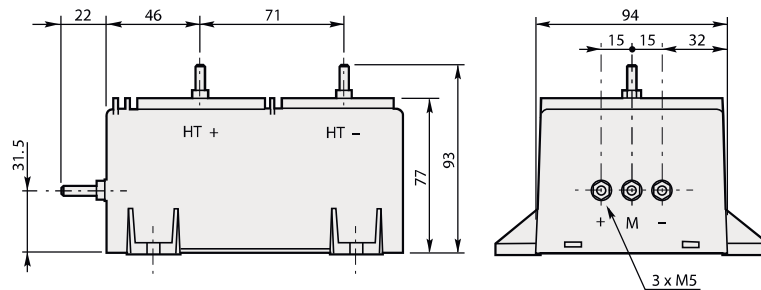

General tolerance: ± 1 mm

Size 1 (VS2000B to VS4200B)